

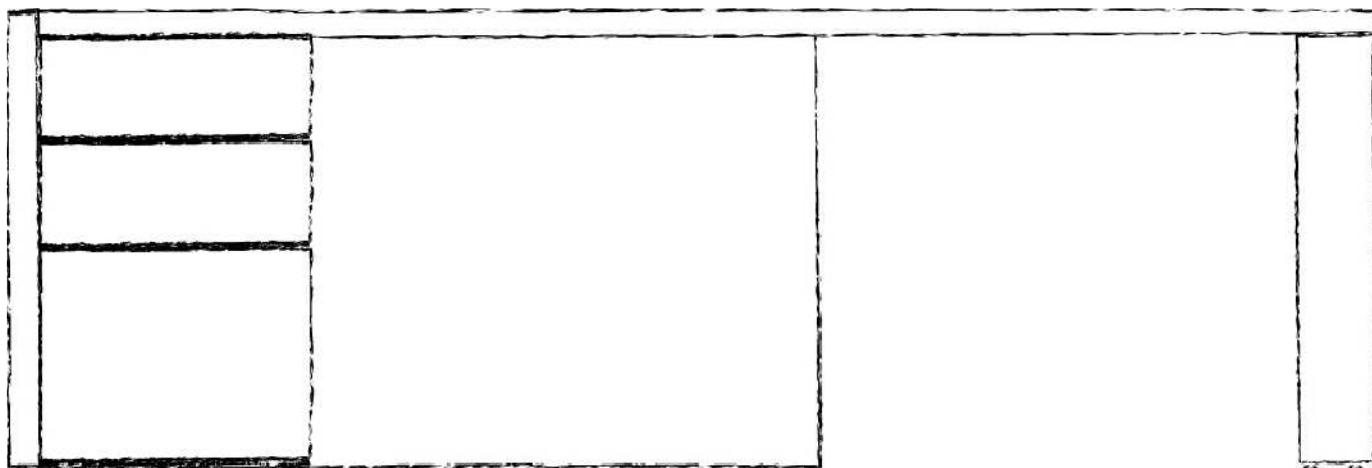

MADE IN ITALY



SCRITTOIO - JONI - WRITING TABLE



227 x 90 h 76 sx  
Scrittoio / Writing table

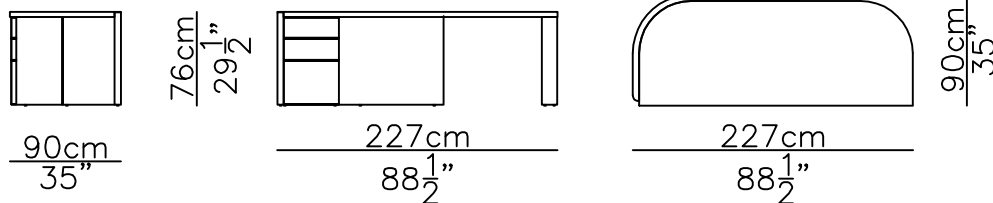

227 x 90 h 76 dx  
Scrittoio / Writing table

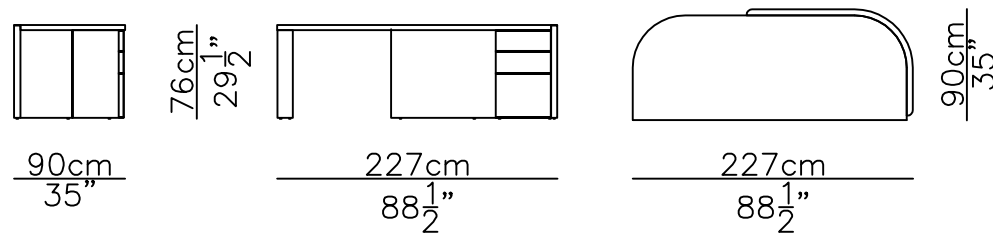

# COMPONENTI

## **Tutte le versioni**

n° 02 - Ranelle

n° 02 - Dadi

n° 01 - Cassettera

n° 01 - Gamba piccola

n° 01 - Gamba grande

n° 08 - Viti a testa svasata M6x30mm

n° 02 - Perni  $\phi$ 6mm x 36mm

n° 03 - Perni  $\phi$ 10mm x 36mm

n° 02 - Grani M6

n° 03 - Grani M10

n° 01 - Chiave per cassetto segreto

n° 01 - Chiave per regolazione piedini

## **Versione Top legno**

n° 02 - Barre filettate M12x735mm

n° 01 - Top in legno

## **Versione Top marmo**

n° 02 - Barre filettate M12x725mm

n° 01 - Sottotop in legno

n° 01 - top in marmo

# COMPONENTS

## All versions

n° 02 - Washer

n° 02 - Nuts

n° 01 - Drawers

n° 01 - Small leg

n° 01 - Big leg

n° 08 - Flared head screw M6x30mm

n° 02 - Metal pin  $\phi$ 6mm x 36mm

n° 03 - Metal pin  $\phi$ 10mm x 36mm

n° 02 - M6 set screw

n° 03 - M10 set screw

n° 01 - Secret drawer key

n° 01 - Adjustable feet wrench

## Versione wood Top

n° 02 - Threaded rod M12x735mm

n° 01 - Wood top

## Versione marble Top

n° 02 - Threaded rod M12x725mm

n° 01 - Wood top support

n° 01 - Marble top

# 1

Posizionare a terra il top dello scrittoio sottosopra. ( Figura 1 - Fase 1 )  
*Place writing table's top on the floor upsidedown.*  
( Picture 1 - Step 1 )

Avvitare le barre filettate M12 al top. ( Figura 1 - Fase 2 )  
*Screw the M12 tie rods on the desk's top. ( Picture 1 - Step 2 )*

Posizionare la gamba piccola sulle barre filettate. Posizionare le ranelle e stringere i dadi. ( Figura 2 - Fase 3 )  
*Place the desk's small leg on the tie rods. Place metal washers on the tie rods and then tighten the metal nuts. ( Picture 2 - Step 3 )*

Avvitare i perni ( $\phi 6\text{mm} \times 36\text{mm}$ ) sul top. ( Figura 3 - Fase 4 )  
*Screw the metal pins ( $\phi 6\text{mm} \times 36\text{mm}$ ) on the top. ( Picture 3 - Step 4 )*

Estrarre i cassetti dalla cassettera lasciando montati i binari.  
( Figura 4 - Fase 5 )  
*Remove the drawers from the chest of drawers.*  
( Picture 4 - Step 5 )

Avvitare la cassettera al piano con le viti a testa svasata M6x30mm.  
( Figura 5 - Fase 6 )  
*Tighten the chest of drawers to the desk's top with M6x30mm flared head screws. ( Picture 5 - Step 6 )*

Stringere i grani M6 con una brugola (Figura 6 - Fase 7)  
*Tighten the M6 set screws with an allen key. (Picture 6 - Step 7)*

Avvitare i perni ( $\phi 10\text{mm} \times 36\text{mm}$ ) sulla gamba grande. (Figura 7 - Fase 8)  
*Screw the metal pins ( $\phi 10\text{mm} \times 36\text{mm}$ ) on the big leg. (Picture 7 - Step 8)*

Posizionare la gamba grande nella corretta posizione allineando i perni metallici e le spine in legno. (Figura 8 - Fase 9)  
*Locate the big leg in the right position by the metal pins and wood dowels provided. (Figura 8 - Fase 9)*

## 2

Avvitare la gamba grande con le viti a testa svasata M6x30mm poste sul fianco della cassettera.

(Figura 9 - Fase 10)

*Screw the big leg to the chest of drawers with flared head screws M6x30mm.*

(Picture 9 - Step 10)

Stringere i grani M10 posti sotto il top con una brugola (Figura 10 - Fase 11)

*Tighten the M10 set screws located under the desk's top with an allen key.*

(Picture 10 - Step 11)

Regolare i piedini sotto ogni gamba in modo che lo scrittoio sia stabile

(Figura 11 - Fase 12)

*Adjust the feet under each leg so that the writing table can be stable.*

(Picture 11 - Step 12)

Inserire i cassetti nel corpo cassettera.

( Figura 12 - Fase 13 )

*Insert the drawers into the chest of drawers.*

( Picture 12- Step 13 )

### **VERSIONE TOP IN MARMO / MARBLE TOP VERSION**

Appoggiare il piano in marmo sulla base in legno. (Figura 14 - Fase 14)

*Lay down the marble slab on the wood support. (Picture 14 - Step 14)*

Montaggio Completato. ( Figura 16 - Fase 16 )

*Assembly completed. ( Picture 16 - Step 16 )*

## Figura 1 - Picture 1

### Fase 1 - Step 1

Vista assonometrica / *Isometric view*

*Nota bene: Posizionare il top capovolto su lastre di polistirolo.  
Maneggiare il top con cura.*  
*To be noted: place the desk's top on styrofoam boards upside down.  
Handle it with care.*

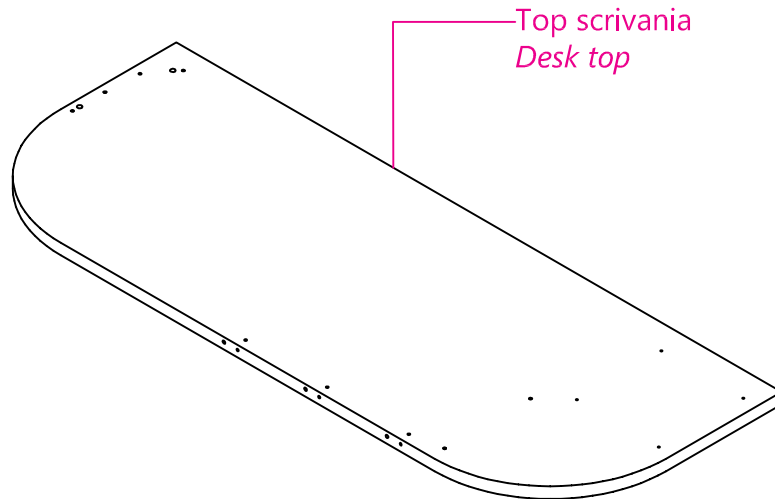

### Fase 2 - Step 2

Vista assonometrica / *Isometric view*

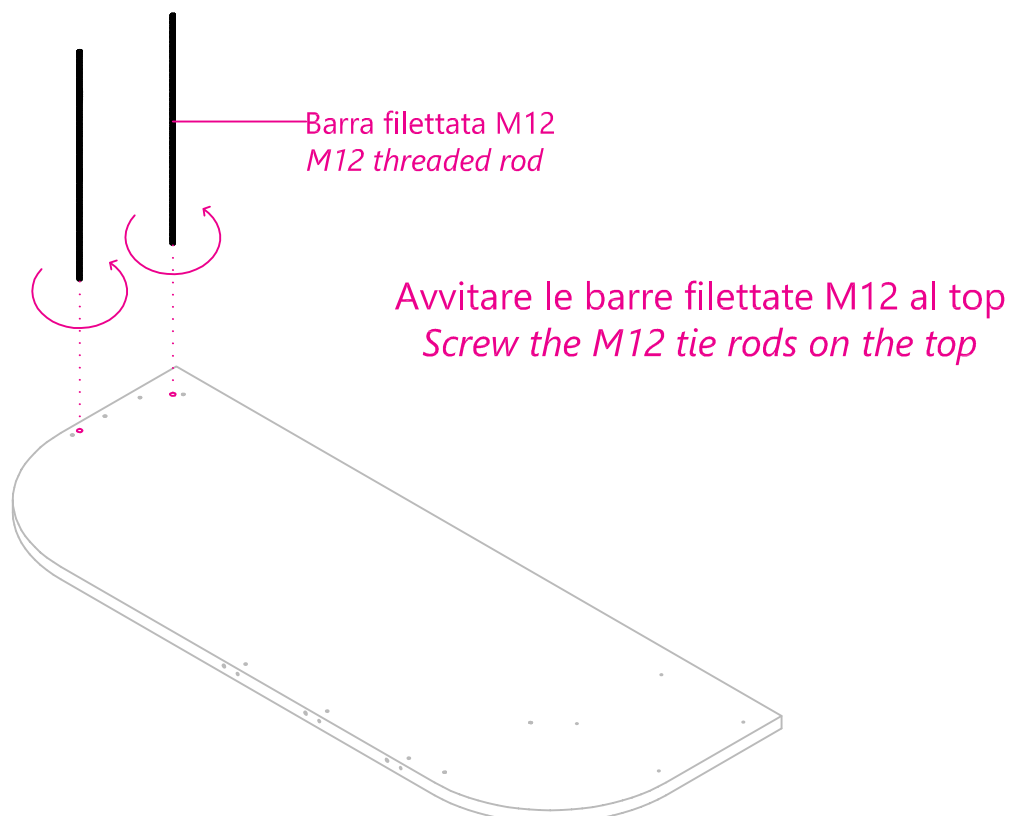

## Figura 2 - Picture 2

### Fase 3 - Step 3

Vista assonometrica / Isometric view

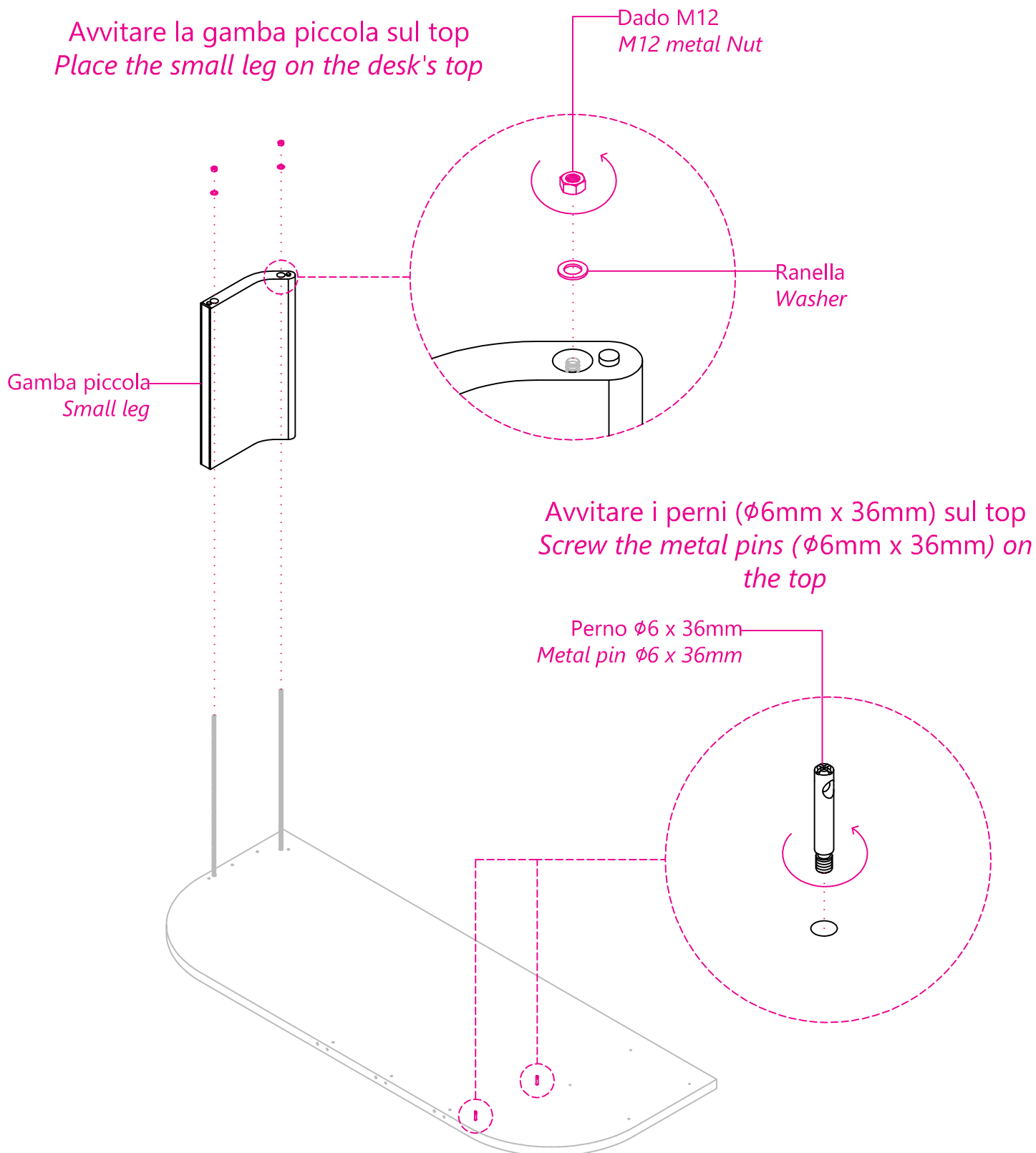



## Figura 3 - Picture 3

### Fase 4 - Step 4

Vista Forntale / Front view

Nota bene: Avvitare i perni tenendo il foro nella corretta direzione.  
*To be noted: screw the metal pin till its hole is in the right position.*

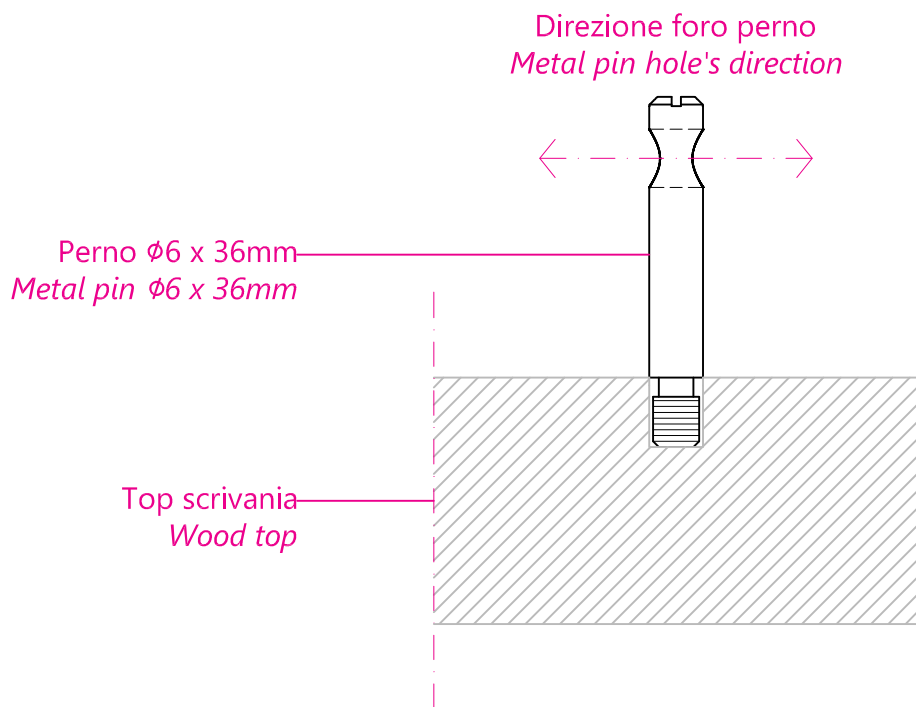

Pianta / Plan



## Figura 4 - Picture 4

### Fase 5 - Step 5

Vista assonometrica / Isometric view

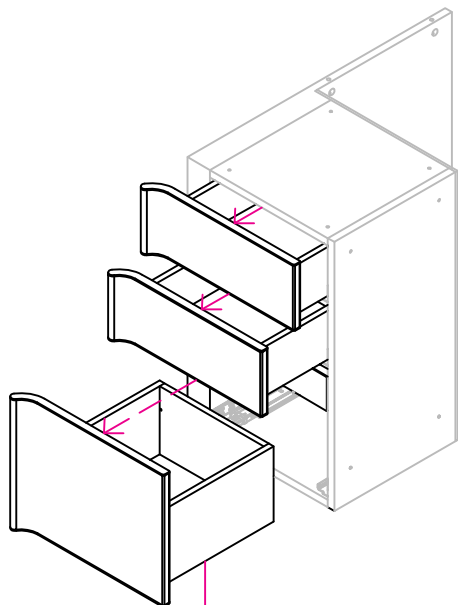

Rimuovere i cassetti  
con frontalino in pelle  
Remove drawers with  
leather finish

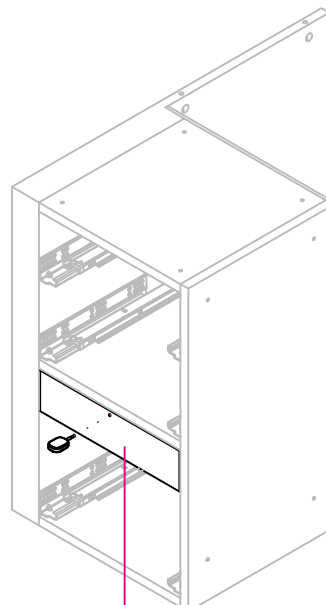

Cassetto segreto  
Secret drawer

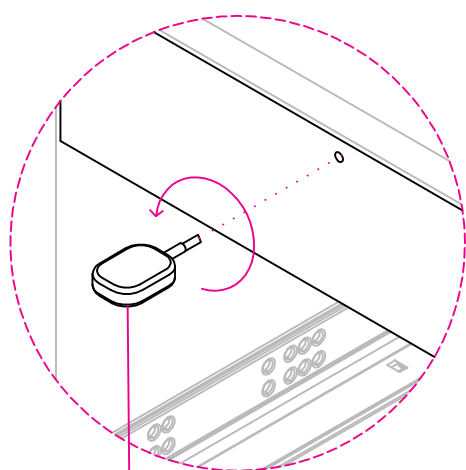

Chiave cassetto  
segreto  
Secret drawer's key

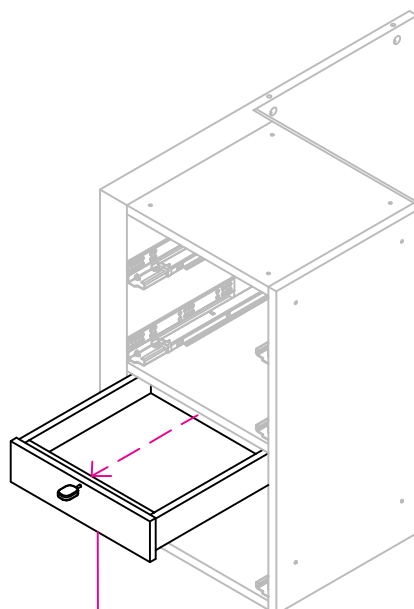

Rimuovere cassetto  
segreto con chiave  
Remove Secret drawer  
with key

## Figura 5 - Picture 5

### Fase 6 - Step 6

Vista assonometrica / Isometric view

Avvitare la cassettera al top  
Screw the chest of drawers to the desk's top

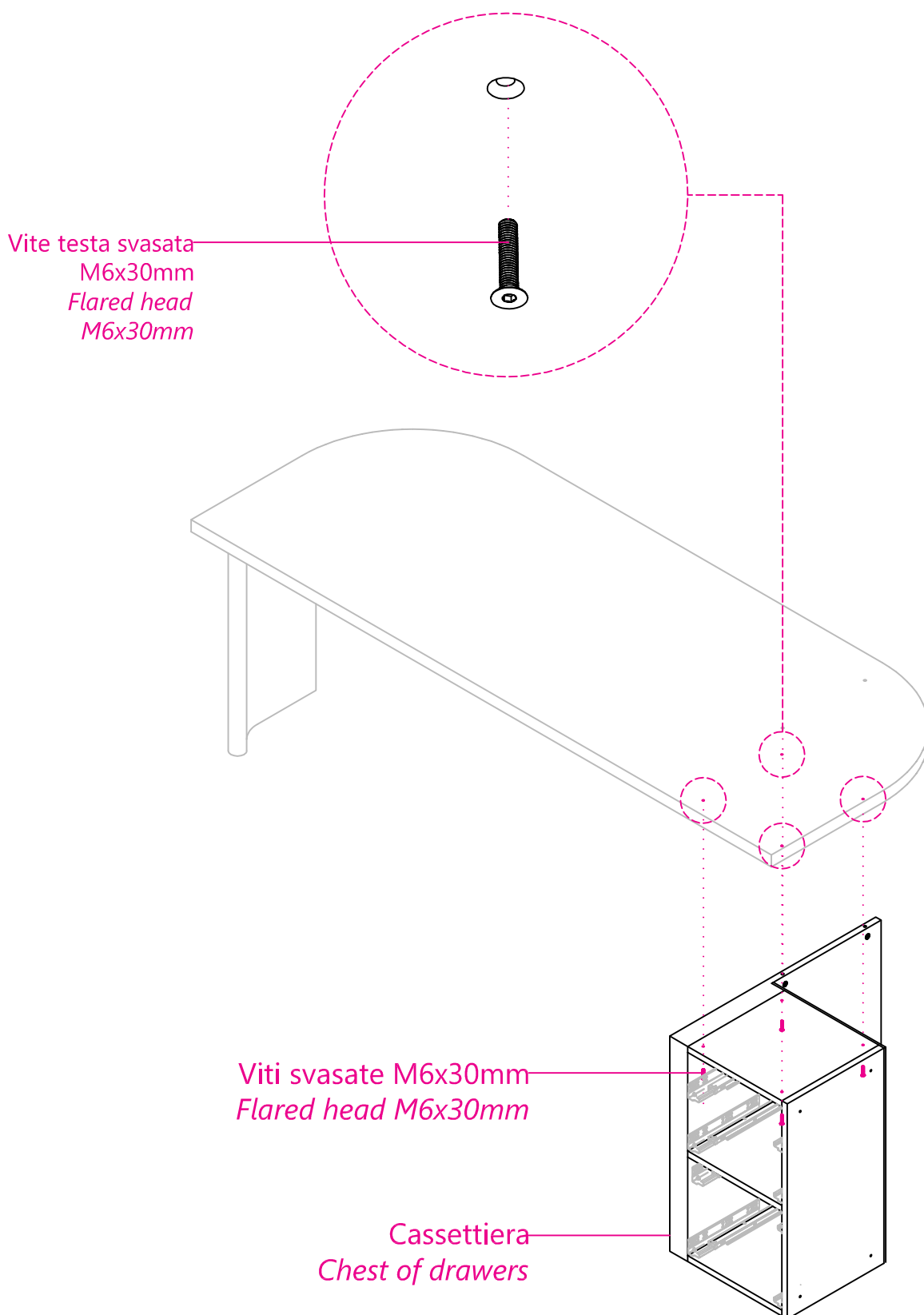

## Figura 6 - Picture 6

### Fase 7 - Step 7

Vista assonometrica / Isometric view

Avvitare i grani M6  
screw the M6 set screws

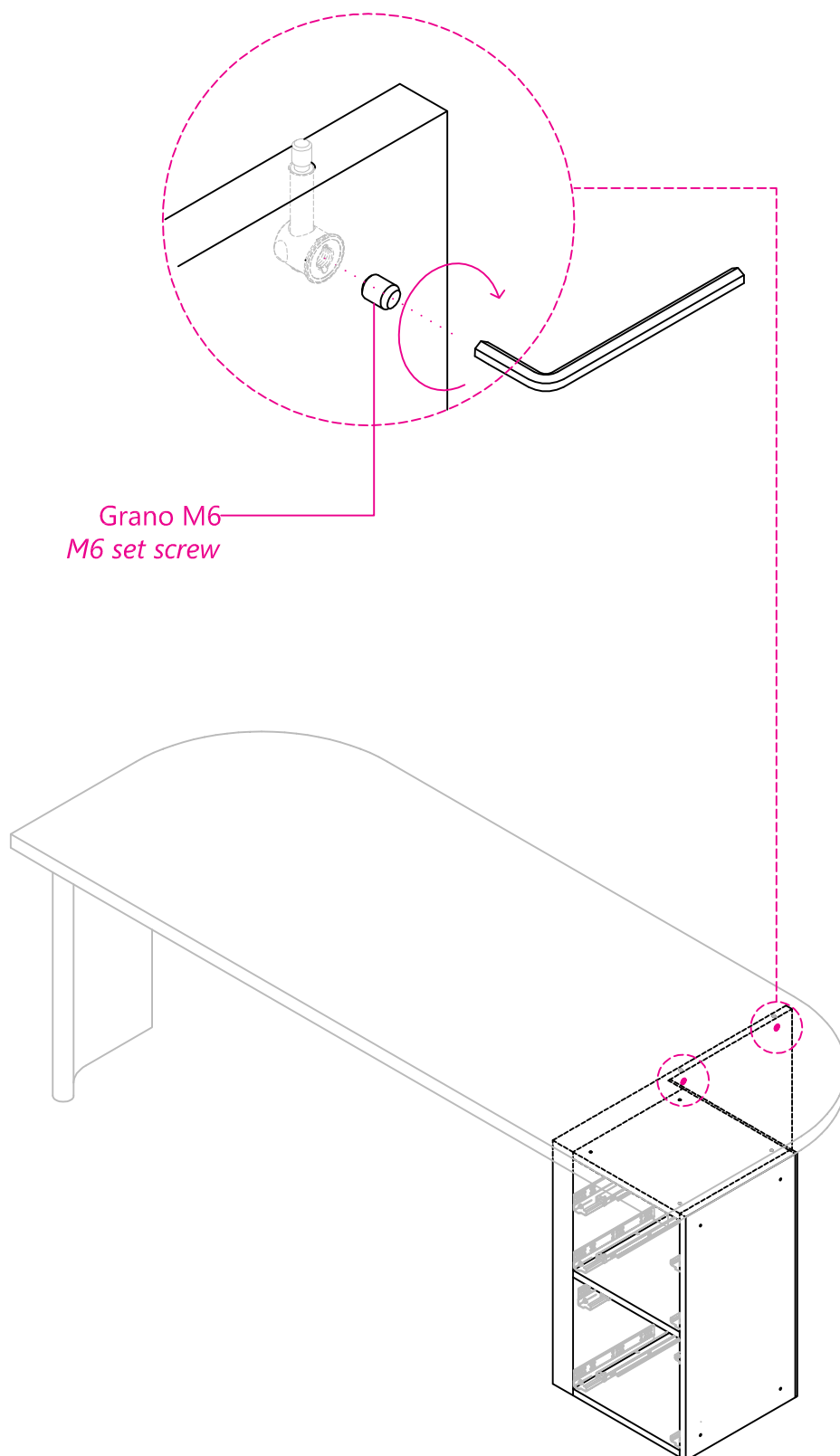

## Figura 7 - Picture 7

### Fase 8 - Step 8

Vista assonometrica / Isometric view

Nota bene: Avvitare i perni tenendo il foro nella corretta direzione.  
To be noted: screw the metal pin till its hole is in the right position.

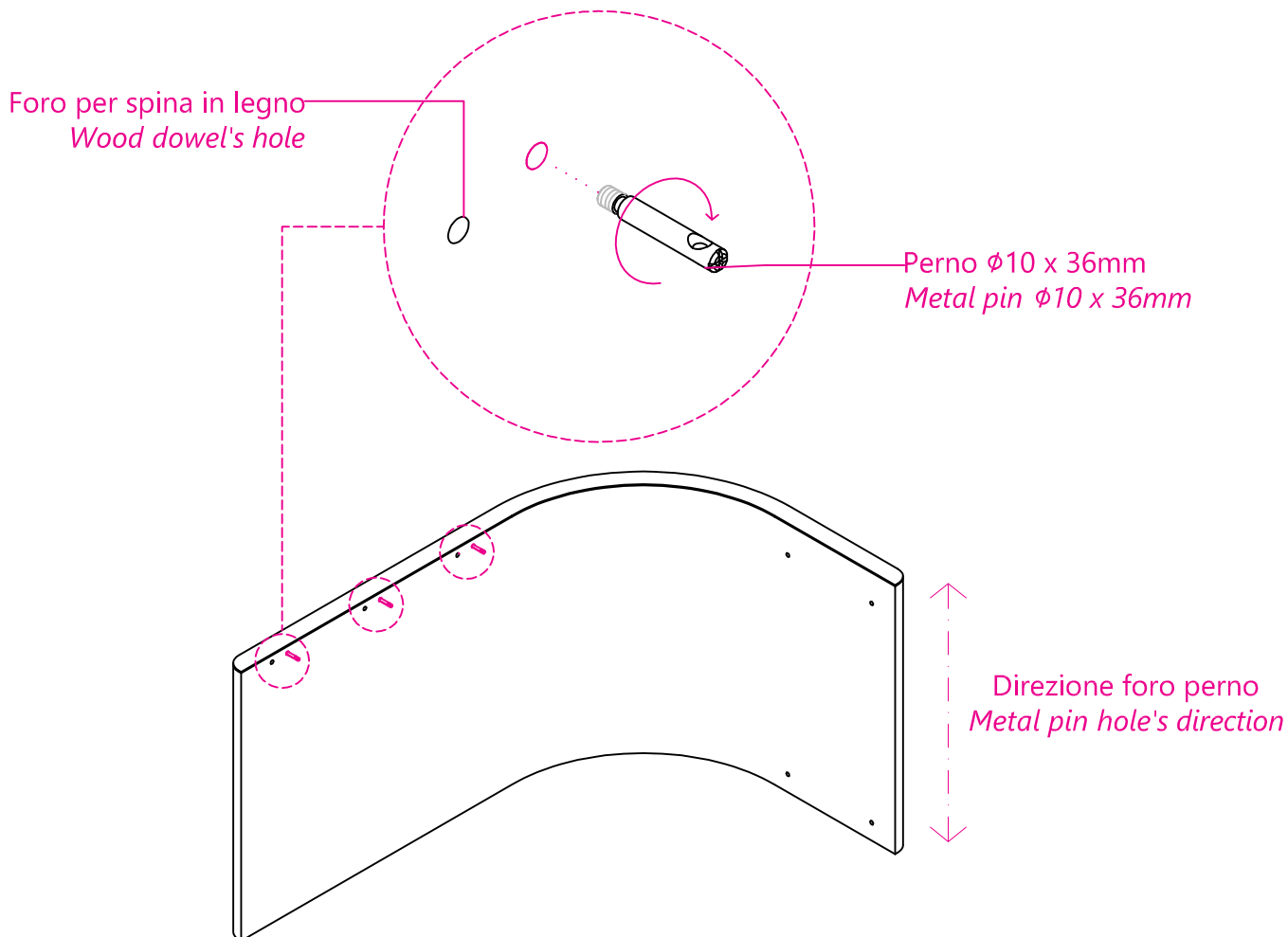

Vista laterale / Lateral view

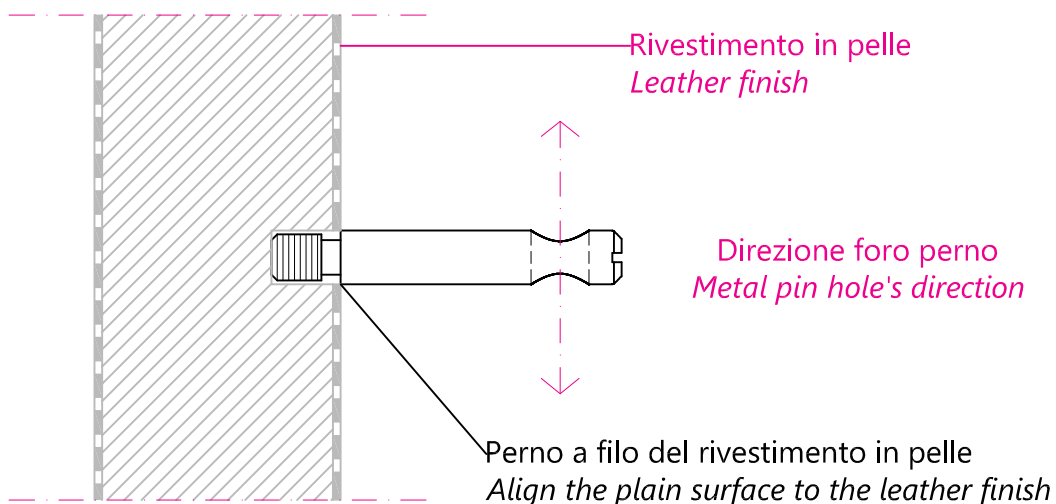

## Figura 8 - Picture 8

### Fase 9 - Step 9

Vista assonometrica / Isometric view

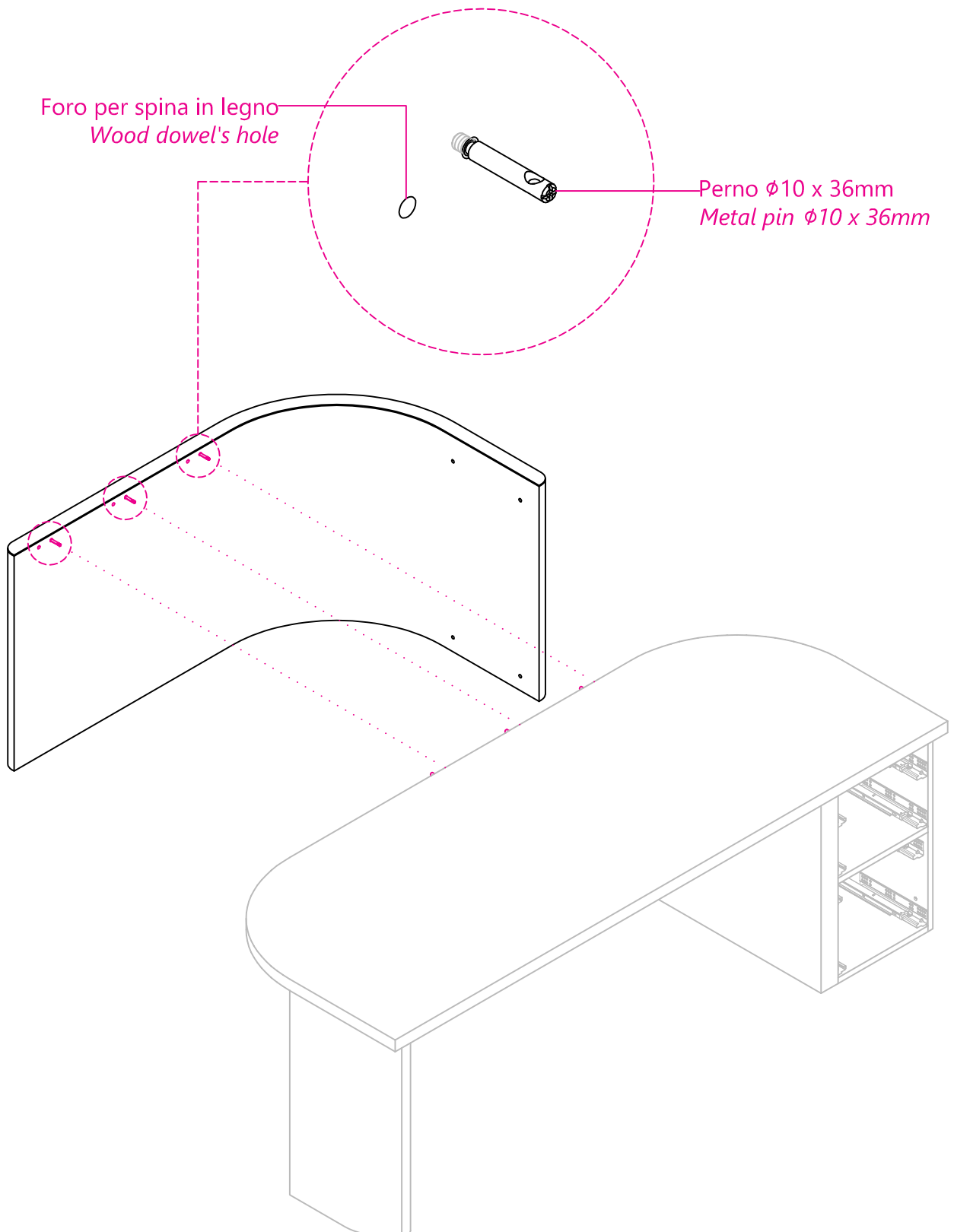

## Figura 9 - Picture 9

### Fase 10 - Step 10

Vista assonometrica / Isometric view

Avvitare la gamba grande  
Screw the big leg

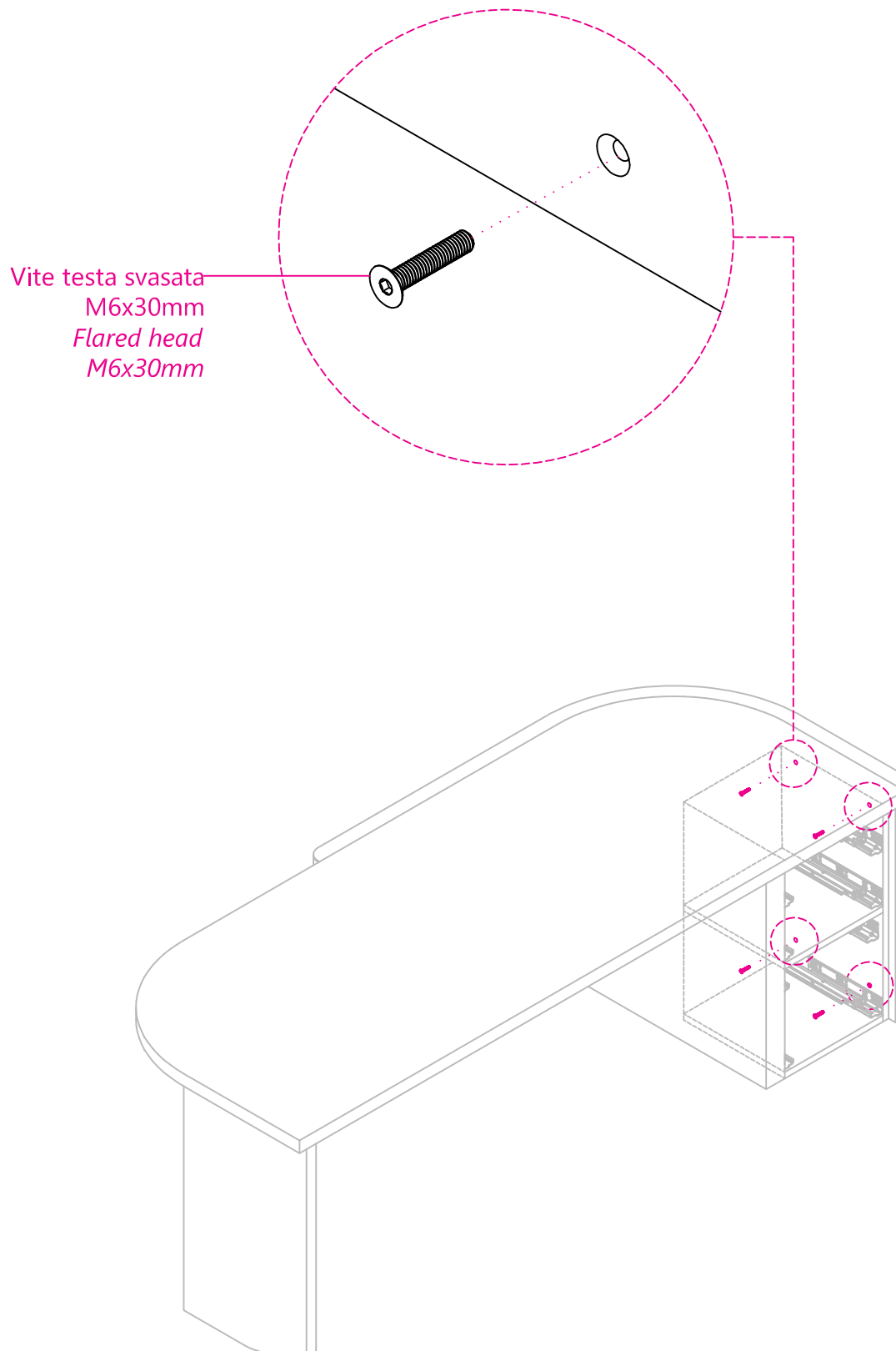

## Figura 10 - Picture 10

### Fase 11 - Step 11

Vista assonometrica / Isometric view

Avvitare i grani M10  
screw the M10 set screws

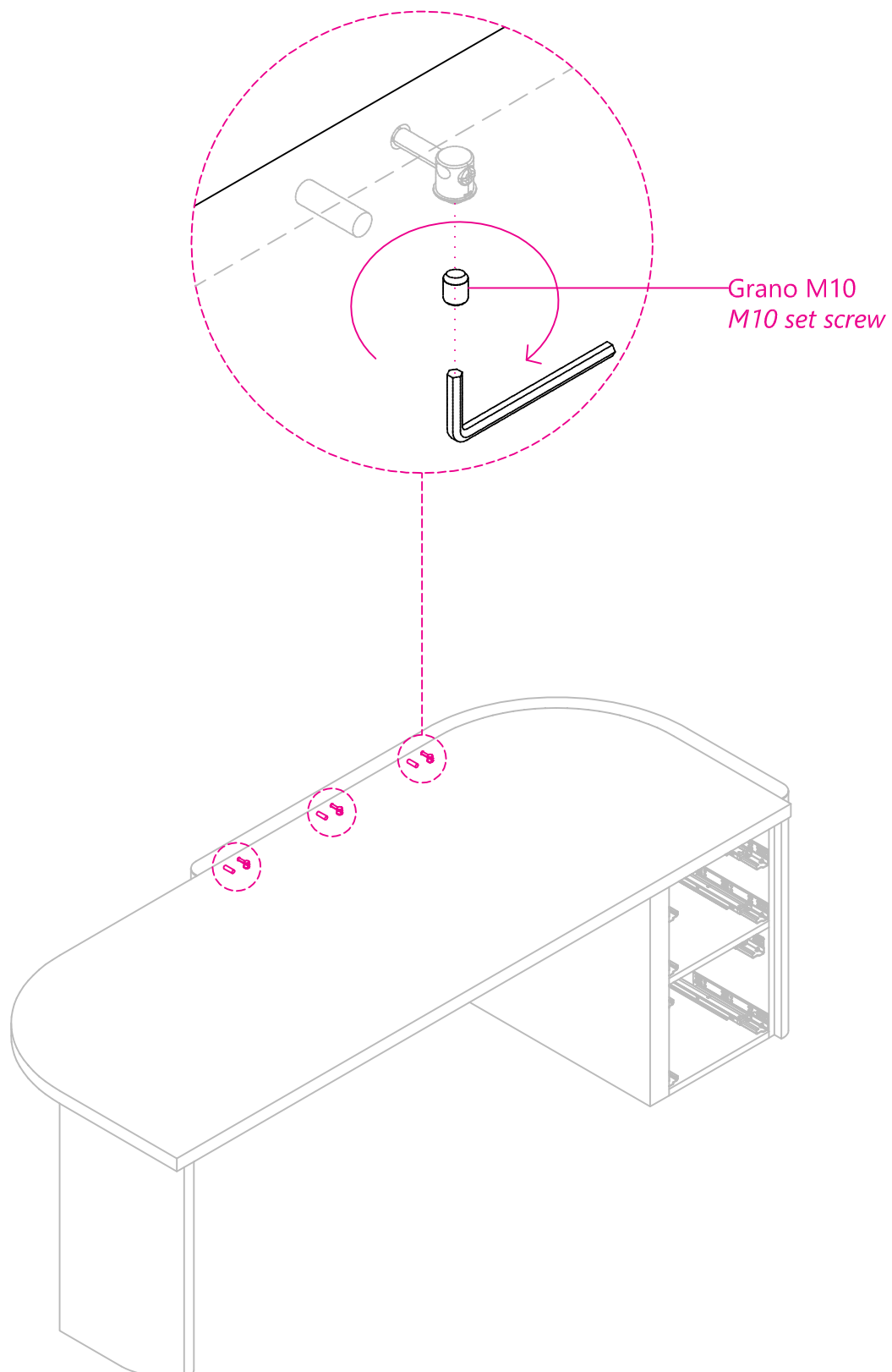



## Figura 11- Picture 11

### Fase 12 - Step 12

Vista frontale / Front view

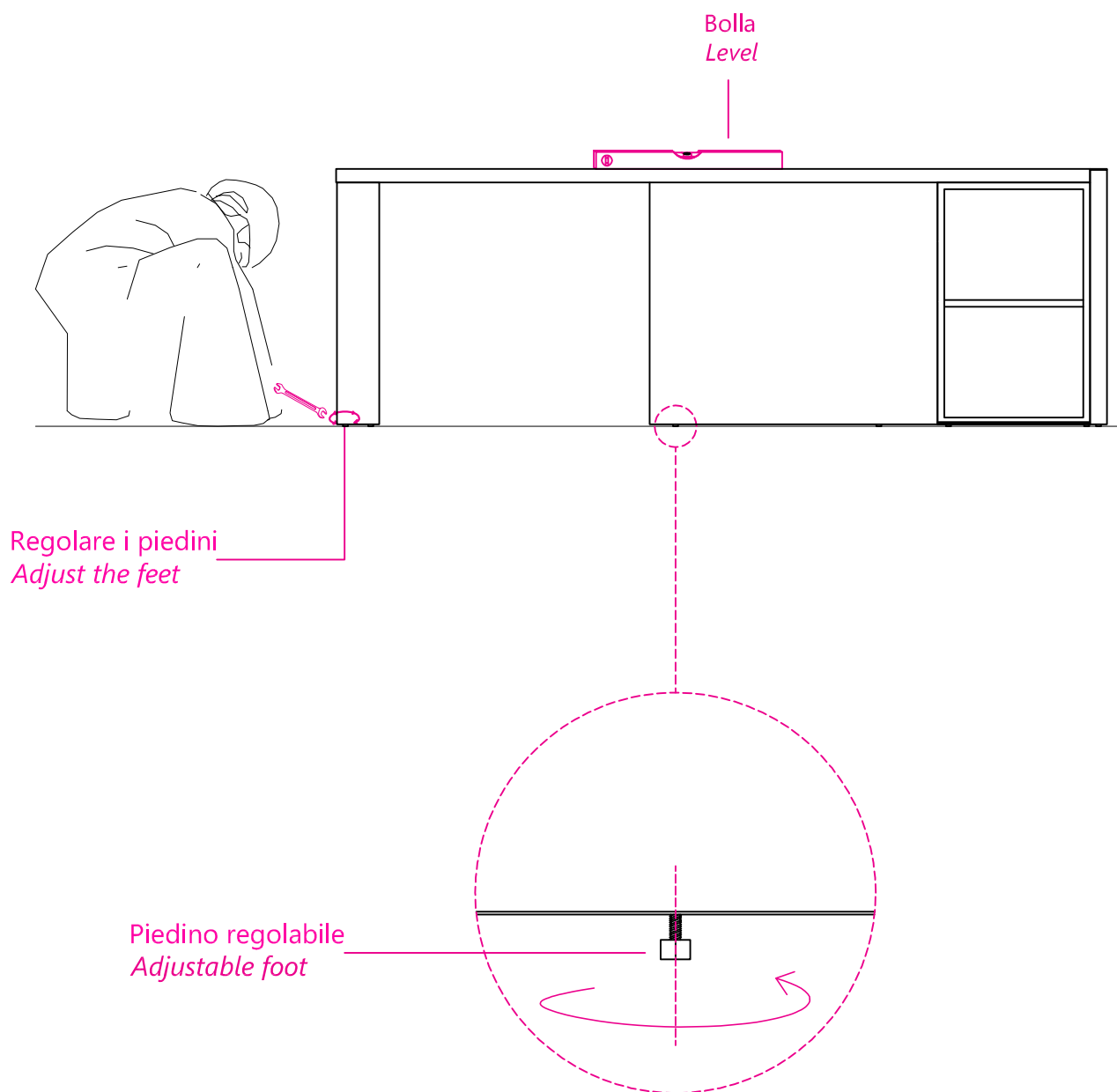

## Figura 12 - Picture 12

### Fase 13 - Step 13

Vista assonometrica / Isometric view

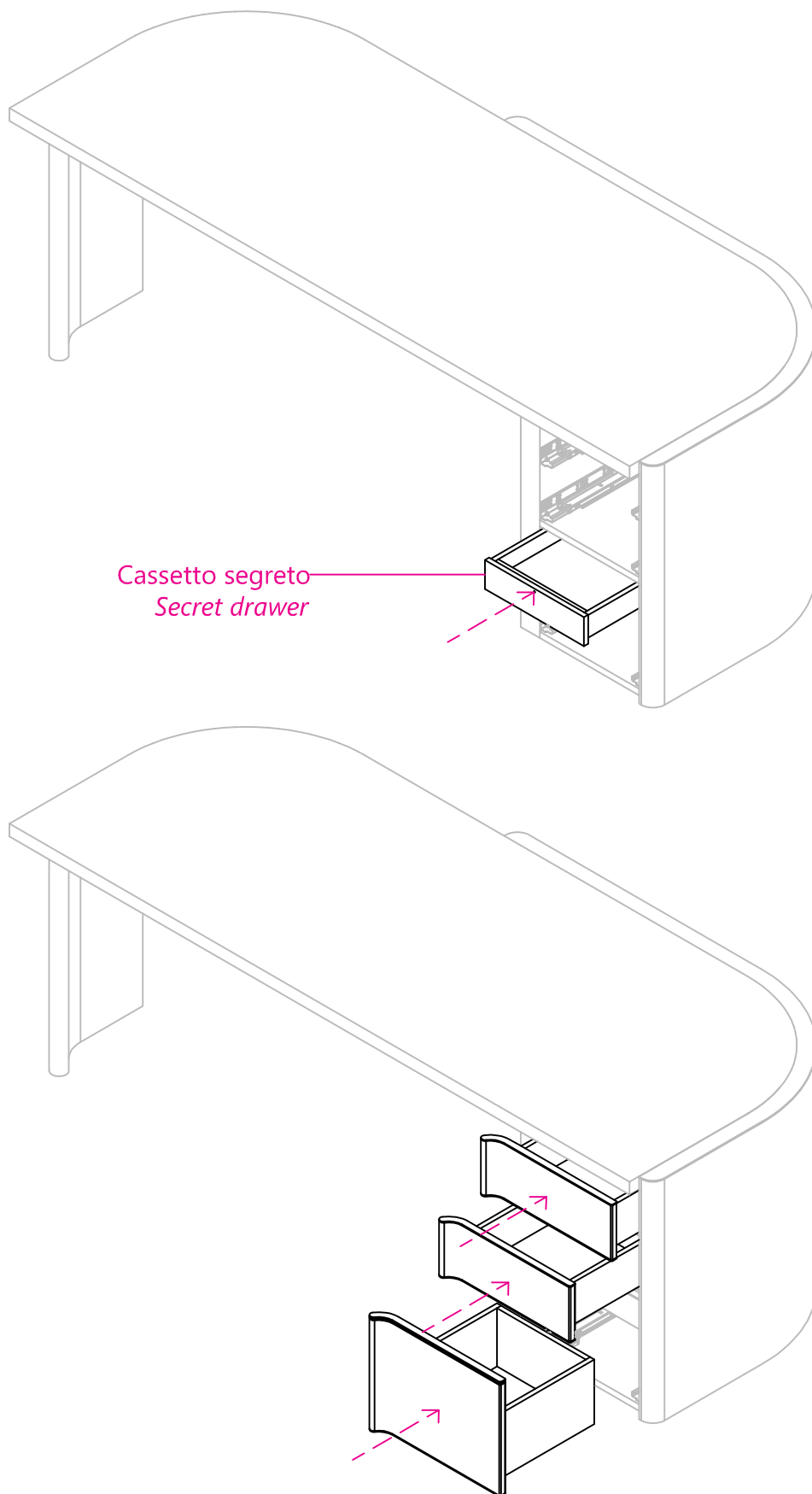

## Figura 13 - Picture 13

### Fase 13 - Step 13

Vista assonometrica / Isometric view

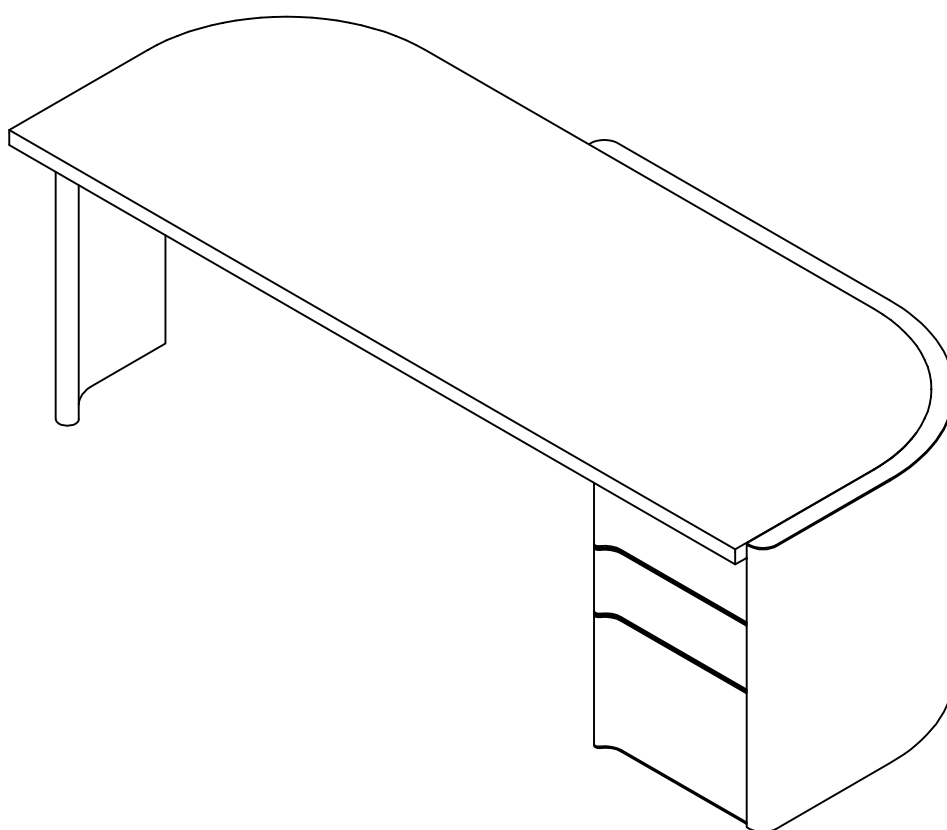

TOP IN MARMO  
*MARBLE TOP*

## Figura 14 - Picture 14

### Fase 14 - Step 14

Vista assonometrica / *Isometric view*

Appoggiare il piano in marmo sulla base in legno.  
*Lay down the marble slab on the wood support.*

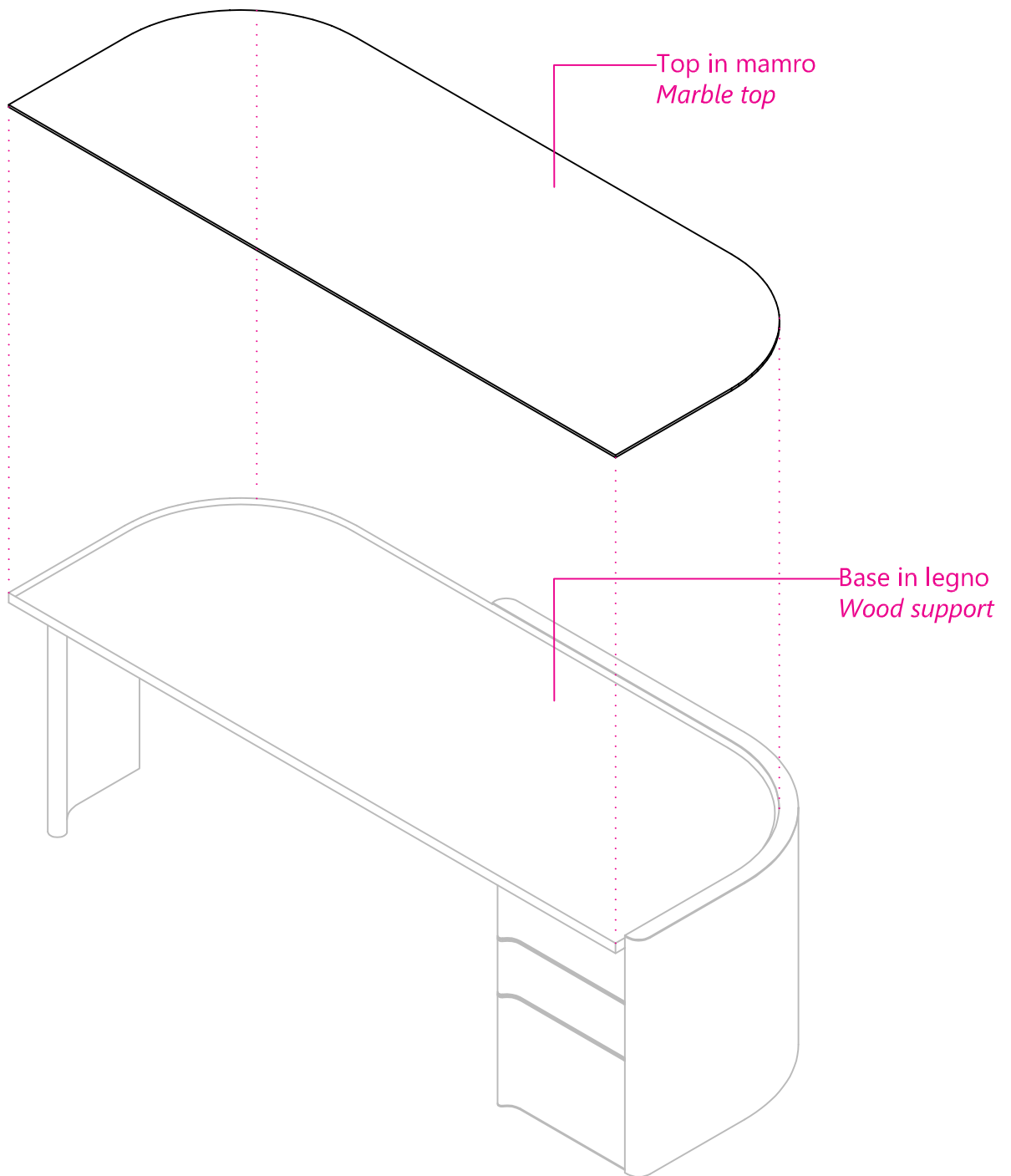

## Figura 15 - Picture 15

### Fase 15 - Step 15

Vista assonometrica / Isometric view

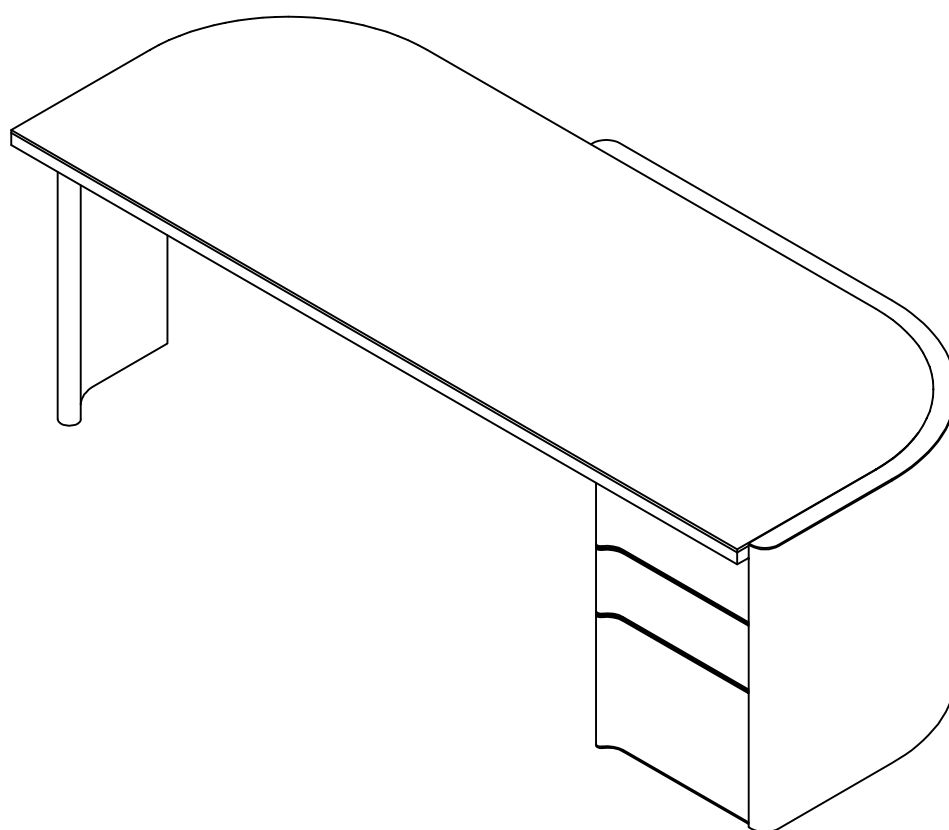

## Figura 16 - Picture 16

### Fase 15 - Step 15

Vista frontale / *Front view*



